

Linear actuator

CAHM-50

Benefits

- Modular
- Robust
- Reliable
- High speed and/or high load
- All metal design



Picture CAHM-5012-BN0300-R00



Connecting diagrams

Motor:
A4 - 3x400 V AC

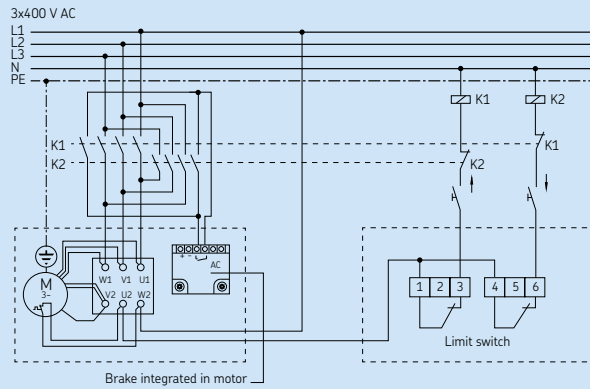
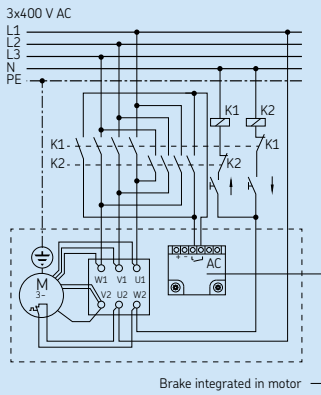

Option 2:
L - Limit switch

Performance diagram

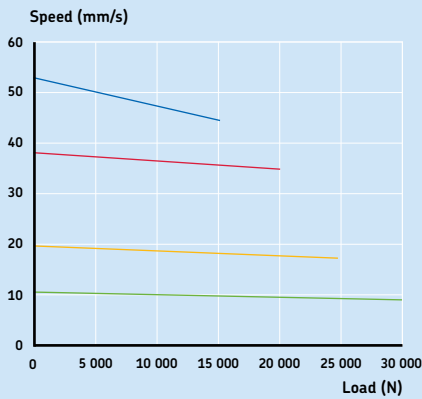

- CAHM-5004
- CAHM-5006
- CAHM-5012
- CAHM-5023

Safety factor load conditions

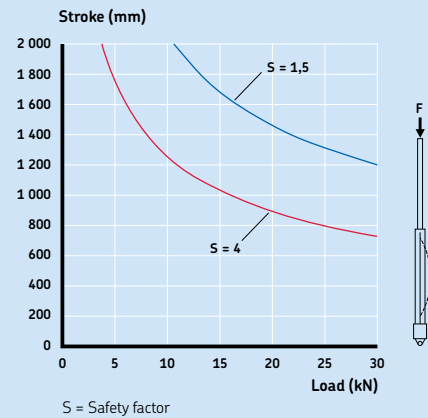

Ordering key

Load [N] / Full Load Speed [mm/s]			
15 000 / 45	20 000 / 35	25 000 / 17	30 000 / 9
4	6	12	23

C A H M - 5 0 - B N 0 - A 4 - R 0 - 0 0 0

Type

Size (Gear Center Distance)

50 mm 5 0

Gear Ratio

4	0 4
6	0 6
12	1 2
23	2 3

Screw Type

Ball screw 40x10 B N

Stroke

100 mm	0 1 0 0
200 mm	0 2 0 0
300 mm	0 3 0 0
400 mm	0 4 0 0
500 mm	0 5 0 0
600 mm	0 6 0 0
700 mm	0 7 0 0

Motor

3x400 VAC A 4

Front Attachment

Rod End R

Option 1 - Brake

No option - Brake is in the motor as standard 0

Option 2

No option
 Limit switch O
 Limit switch and potentiometer (1 000 Ω) L
 C

Customer option

0 0 0

© SKF is a registered trademark of the SKF Group.

© SKF Group 2015

The contents of this publication are the copyright of the publisher and may not be reproduced (even extracts) unless prior written permission is granted. Every care has been taken to ensure the accuracy of the information contained in this publication but no liability can be accepted for any loss or damage whether direct, indirect or consequential arising out of the use of the information contained herein.

PUB MT/P8 15708 EN · October 2015

