

Servo actuator SEMC



Contents

Servo actuator SEMC	4
Product description	5
SEMC Linear unit	6
SEMC Servomotor, inline configuration	8
SEMC Servomotor, parallel configuration	10
Ordering key actuator	12

Servo actuator SEMC



Features

- High performance roller screw for high speed (up to 600 mm/s) and acceleration (up to 9,5 m/s²) requests
- High dynamic servomotor for high speed and acceleration requests
- Optional anti-rotation device
- Adjustable external proximity switches
- Optional lubricant for food grease compatibility
- Optional fail safe brake, absolute encoder on servomotor
- Recirculation roller screw with low lead (up to 1 mm) available on demand

Benefits

- Long lifetime, thanks to roller screw technology
- Aluminium body to save kg and limit total weight of the actuator
- Customized motor adapter for highest flexibility (max motor section 90 mm)
- Compact solution with high power density

Product description

In addition to standard electrical cylinder product range, SKF offers an extensive customization program that is able to fulfill specific application needs. This is important for SKF recognition as a knowledge engineering company and solution provider.

The SEMC actuator is one of the customized solutions designed by SKF. The application requirements consisted of a dimensionally compact and lightweight actuator with a long lifetime, high speed and high acceleration.

The SKF solution is based on a BRC15x5 or 8 roller screw, with a full aluminium body, resulting in a very compact solution weighing less than 7 kg including the motor, but robust thanks to the roller screw technology used inside.

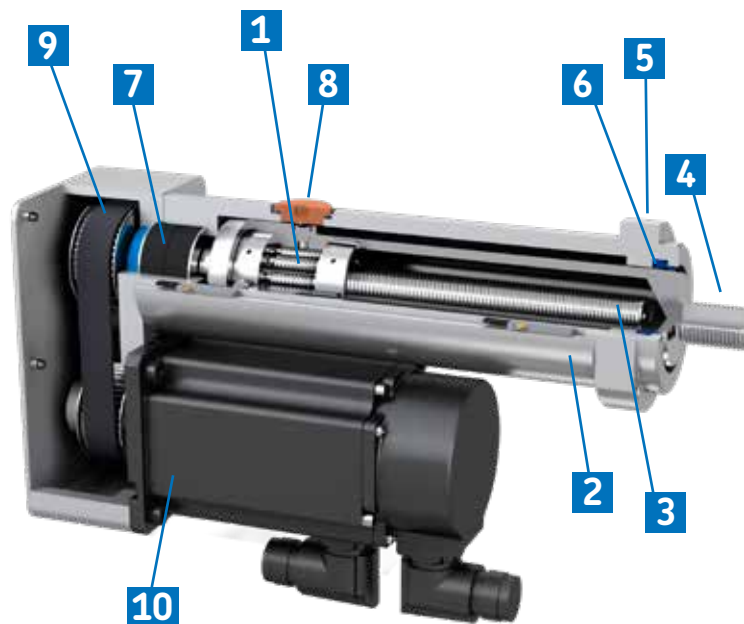

- 1** High quality SKF planetary roller screw with backlash elimination
- 2** Aluminium body
- 3** Steel push rod
- 4** Male thread on push rod (customization upon request)
- 5** Front mount
- 6** Scraper on the front to keep out contaminants
- 7** High quality SKF bearings
- 8** Plug for direct grease access on roller screw nut body
- 9** Pulleys/belt transmission (ratio 1:1)
- 10** Servomotor

SEMC

Linear unit



Technical data

Designation	Symbol	Unit	SEMC1505 w/o motor		SEMC1508 w/o motor	
			P10 interface	L10 interface	P10 interface	L10 interface
Performance data						
Max. dynamic axial force	F_{max}	kN	7,4	10	4,5	6,2
Max. static axial force	F_{0max}	kN	7,4	10	4,5	6,2
Dynamic load capacity	C	kN	26	26	27,4	27,4
Maximum torque to reach F_{max}	M_{max}	Nm	7,5	10	7,5	10
Max. linear speed	V_{max}	mm/s	375	375	600	600
Max. rotational speed	n_{max}	1/min	4 500	4 500	4 500	4 500
Max. acceleration	a_{max}	m/s ²	6	6	9,5	9,5
Duty cycle	D_{unit}	%	100	100	100	100
Mechanical Data						
Screw type	-	-	Roller screw		Roller screw	
Screw diameter	d_{screw}	mm	15	15	15	15
Screw lead	p_{screw}	mm	5	5	8	8
Lead accuracy	-	-	G5	G5	G5	G5
Stroke	s	mm	up to 125	up to 125	up to 125	up to 125
Internal overstroke each side	s_0	mm	2	2	2	2
Backlash	$s_{backlash}$	mm	0	0	0	0
Efficiency	η_{lu}	%	78	80	77	79
Gear reduction	i	-	1	1	1	1
Weight @ 0 mm stroke	m_{lu}	kg	3,7	3,7	3,7	3,7
Δ Weight per 50 mm stroke	Δm	kg	0,4	0,4	0,4	0,4
Environment						
Ambient temperature	$T_{ambient}$	°C	0...+40	0...+40	0...+40	0...+40
Degree of protection	IP	-	54S	54S	54S	54S

Lifetime diagram

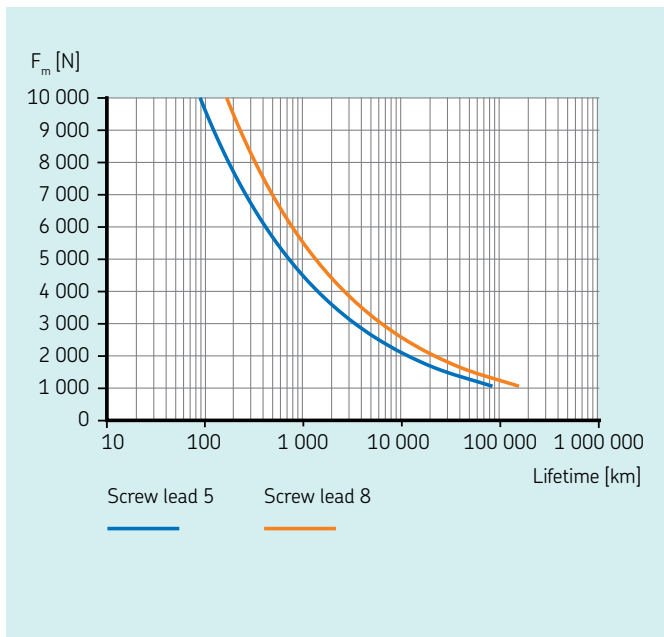

Dimensional drawing parallel configuration

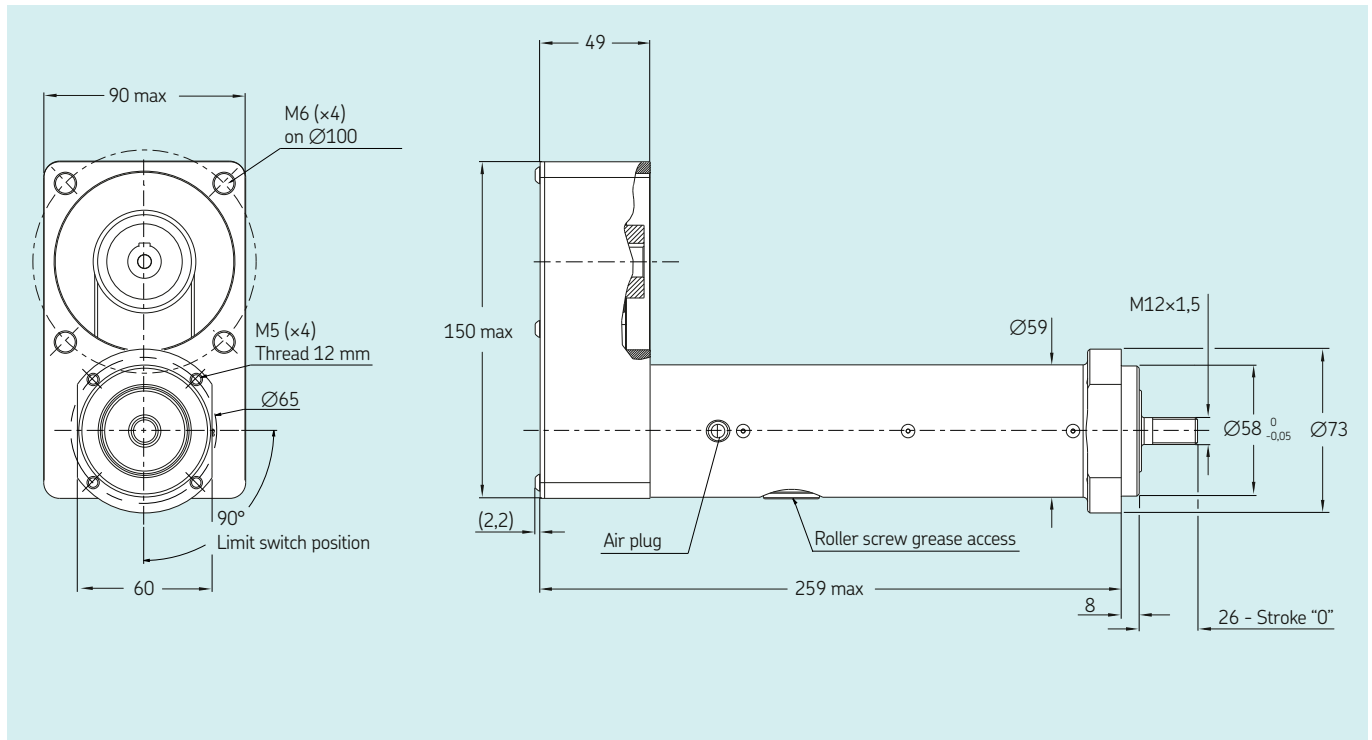

Dimensional drawing inline configuration

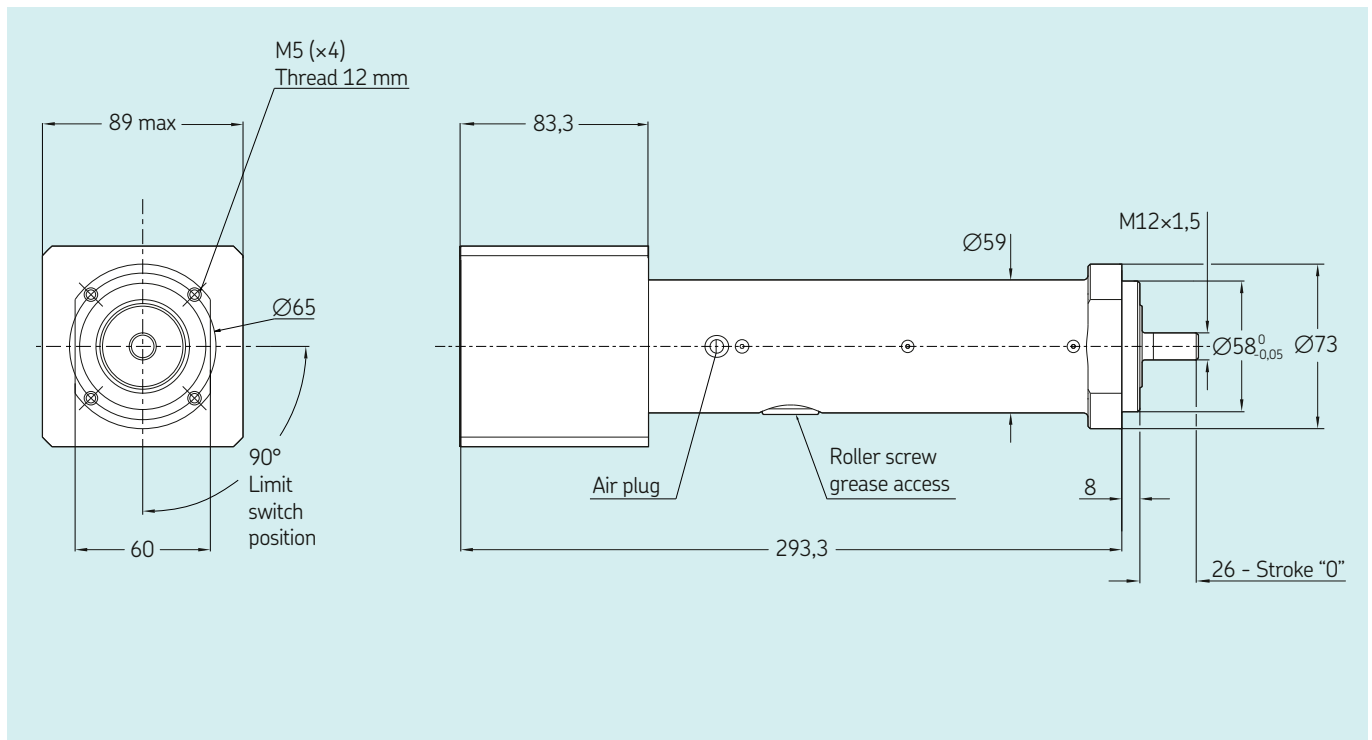

Ordering key

See page 12



SEMC

Servomotor, inline configuration



Technical data

Designation	Symbol	Unit	SEMC1505 Lenze MCM	SEMC1508 Lenze MCM
Performance data				
Continuous force @ zero speed	F_{c0}	kN	2,9	1,8
Continuous force @ max speed	F_c	kN	2,4	1,5
Peak force @ zero speed	F_{p0}	kN	6,5	4,0
Peak force @ max speed	F_p	kN	6,5	4,0
Dynamic load capacity	C^p	kN	26	27,4
Holding force (motorbrake option)	F_{hold}	kN	4,1	2,6
Max. linear speed	v_{max}	mm/s	250	400
Max. acceleration	a_{max}	m/s^2	6	9,5
Duty cycle	D_{unit}	%	100	100
Mechanical Data				
Screw type	-	-	Roller screw	Roller screw
Screw diameter	d_{screw}	mm	15	15
Screw lead	p_{screw}	mm	5	8
Lead accuracy	-	-	G5	G5
Stroke	s	mm	up to 125	up to 125
Internal overstroke each side	s_0	mm	2	2
Backlash	$s_{backlash}$	mm	0	0
Gear reduction	i	-	1	1
Weight @ 0 mm stroke	m_{lu}	kg	6,5	6,5
Δ Weight per 50 mm stroke	Δm	kg	0,4	0,4
Environment				
Ambient temperature	$T_{ambient}$	$^{\circ}C$	0...+40	0...+40
Degree of protection	IP	-	54S	54S

Performance diagram

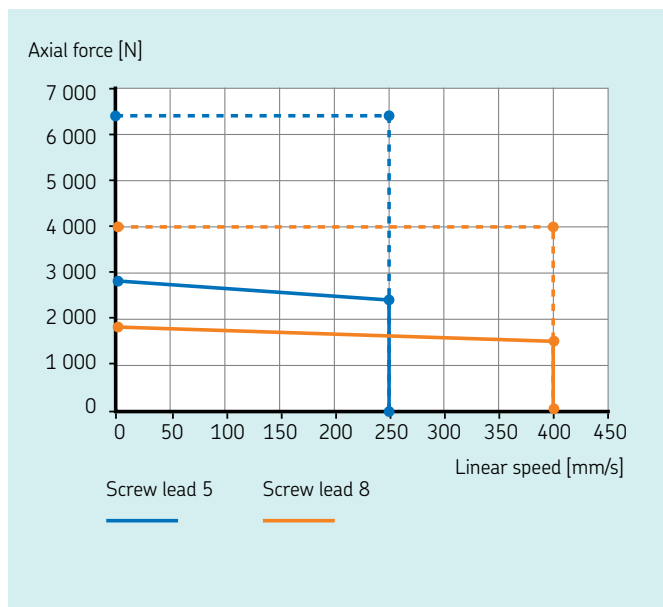

Lifetime diagram

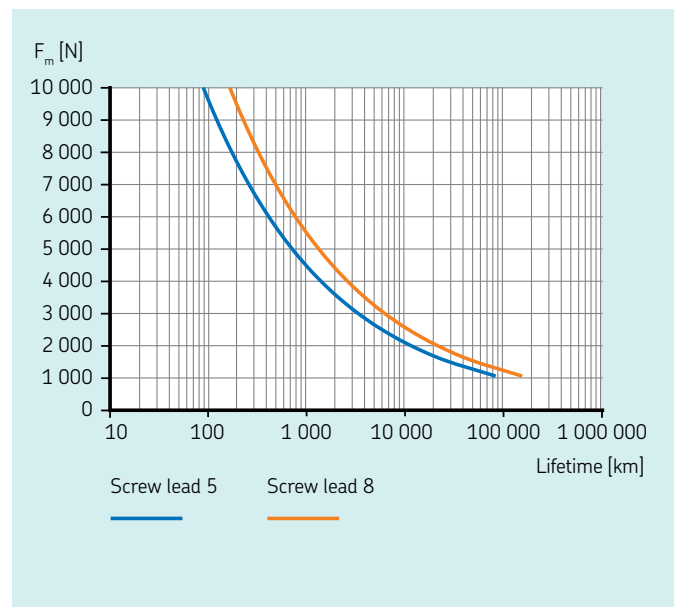

Dimensional drawing

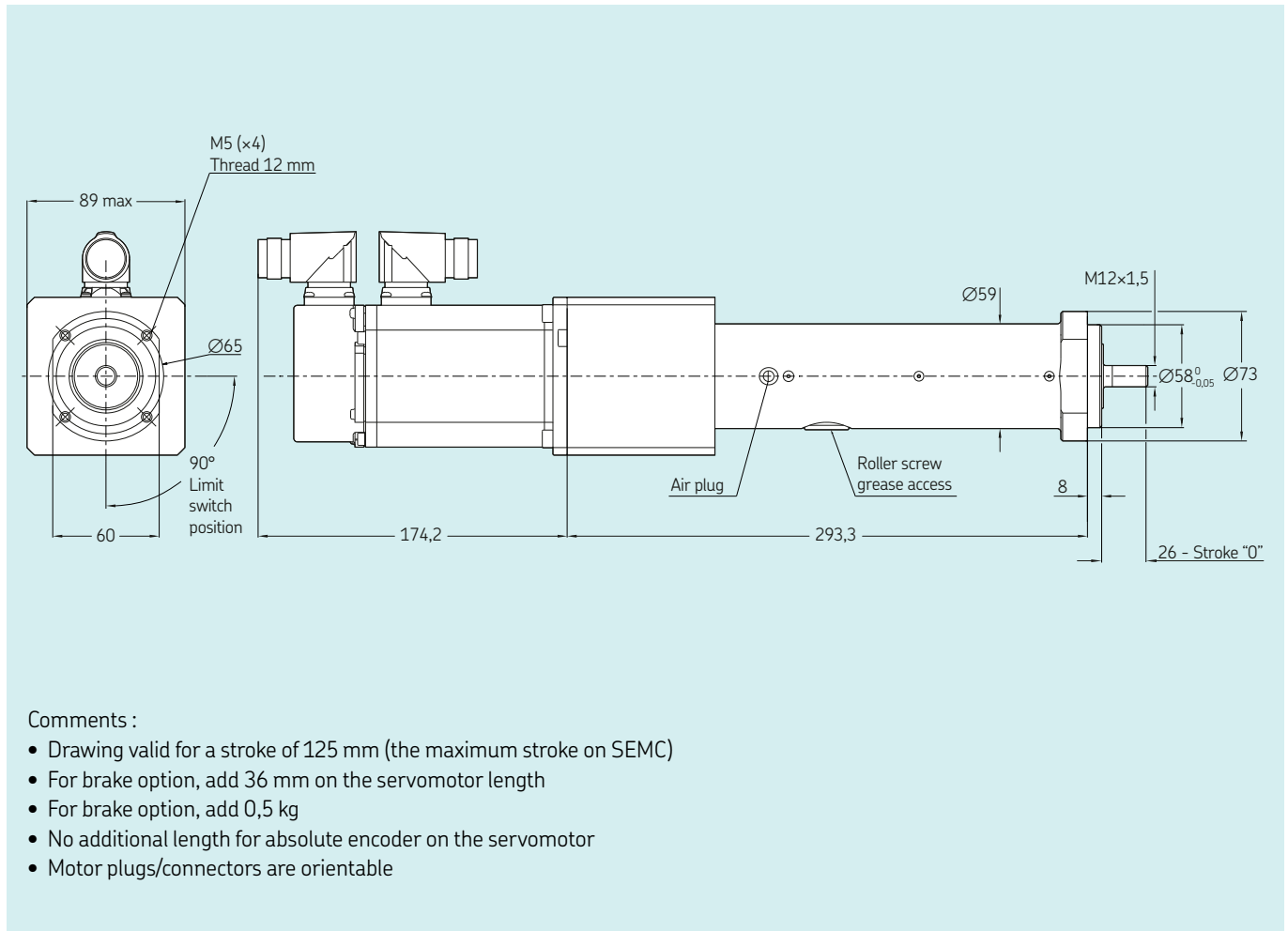

Ordering key

See page 12

SEMC

Servomotor, parallel configuration



Technical data

Designation	Symbol	Unit	SEMC1505 Lenze MCM	SEMC1508 Lenze MCM
Performance data				
Continuous force @ zero speed	F_{c0}	kN	2,8	1,8
Continuous force @ max speed	F_c	kN	2,4	1,5
Peak force @ zero speed	F_{p0}	kN	6,4	3,9
Peak force @ max speed	F_p	kN	6,4	3,9
Dynamic load capacity	C^p	kN	26	27,4
Holding force (motorbrake option)	F_{hold}	kN	4,2	2,7
Max. linear speed	v_{max}	mm/s	250	400
Max. acceleration	a_{max}	m/s^2	6	9,5
Duty cycle	D_{unit}	%	100	100
Mechanical Data				
Screw type	-	-	Roller screw	Roller screw
Screw diameter	d_{screw}	mm	15	15
Screw lead	p_{screw}	mm	5	8
Lead accuracy	-	-	G5	G5
Stroke	s	mm	up to 125	up to 125
Internal overstroke each side	s_0	mm	2	2
Backlash	$s_{backlash}$	mm	0	0
Gear reduction	i	-	1	1
Weight @ 0 mm stroke	m_{lu}	kg	6,5	6,5
Δ Weight per 50 mm stroke	Δm	kg	0,4	0,4
Environment				
Ambient temperature	$T_{ambient}$	$^{\circ}C$	0...+40	0...+40
Degree of protection	IP	-	54S	54S

Performance diagram

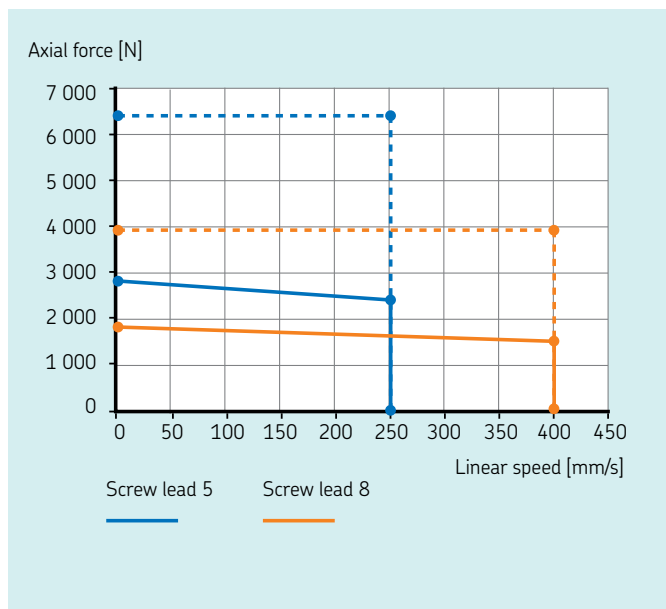

Lifetime diagram

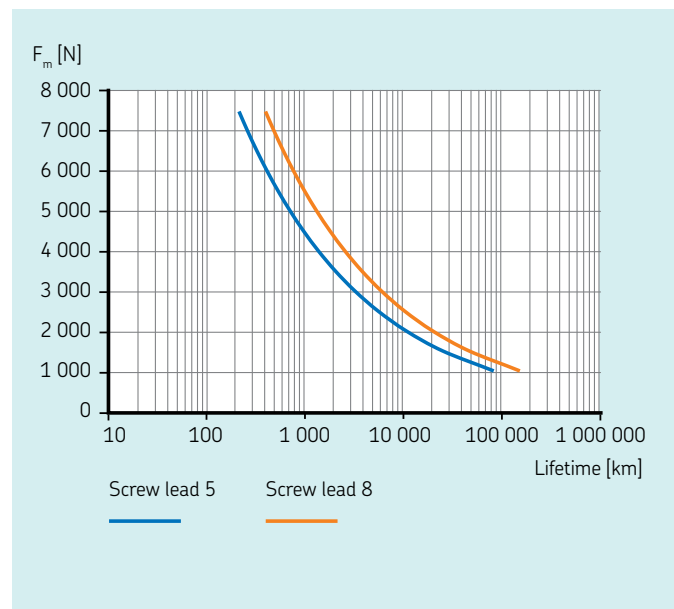

Dimensional drawing

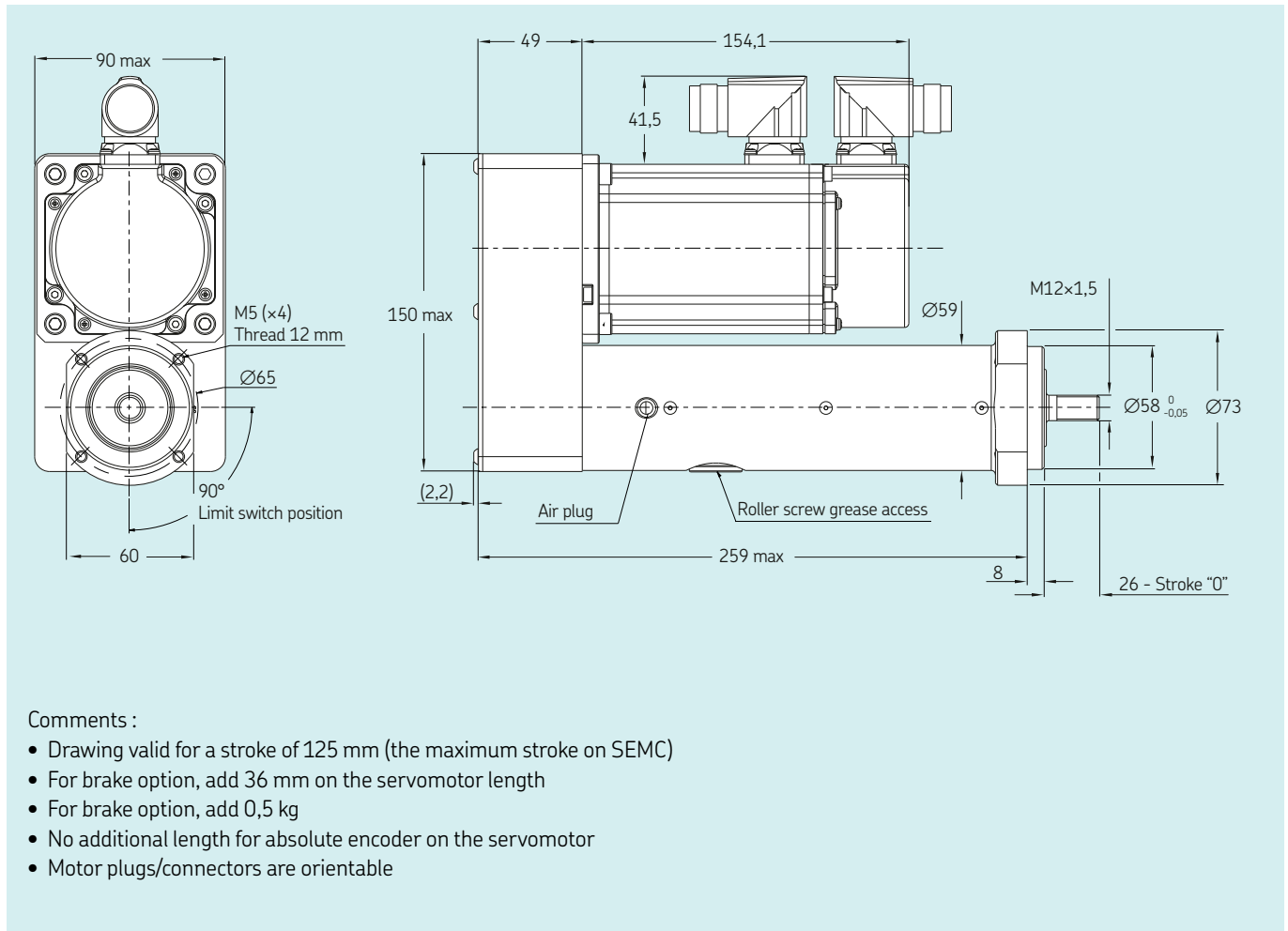

Ordering key

See page 12

Ordering key

Linear units

S E M C - S - 1 5 0 8 - 1 2 5 - F M A F - P 1 0 Z Z Z 1 B Y A 1

Type

Design
 U Linear unit only
 S Servo motor

Screw diameter

Screw lead
 05 5 mm
 08 8 mm

Stroke (mm)

Rear attachment
 F Front plate
 Z Custom

Front attachment
 M Male thread
 N No attachment (female thread)
 Z Custom

Anti-rotation
 A Anti-rotation
 N No anti-rotation

Limit switches 1)
 F 2 limit switches and 1 home switch
 S 2 limit switches only
 M 1 limit switch and 1 home switch
 L 1 limit switch only
 H Home switch only
 N No switch

1) The limit switches configuration can be limited by the stroke length

S E M C - **S** - **1 5 0 8** - **1 2 5** - **F M A F** - **P 1 0 Z Z Z 1 B Y A 1**

Linear unit interface

- L Inline interface
- P Parallel interface

Interface and gear ratio

- 10 ratio 1:1

Motor/drive combination code

- ZZZ On request

Feedback

- 1 Resolver
- 2 Absolute encoder Hiperface

EM brake

- B Brake 24 VDC
- N No brake

Motor drive

- Y Drive included
- N No drive

Drive fieldbus

- A CanOpen
- B Devicenet
- C Ethercat
- D Ethernet
- E Powerlink MN/CN
- F Powerlink CN
- G Profibus
- H Profinet
- N No fieldbus

Power and signal cables

- 1 5m
- 2 10m
- 3 15m
- 4 20m
- N No cable



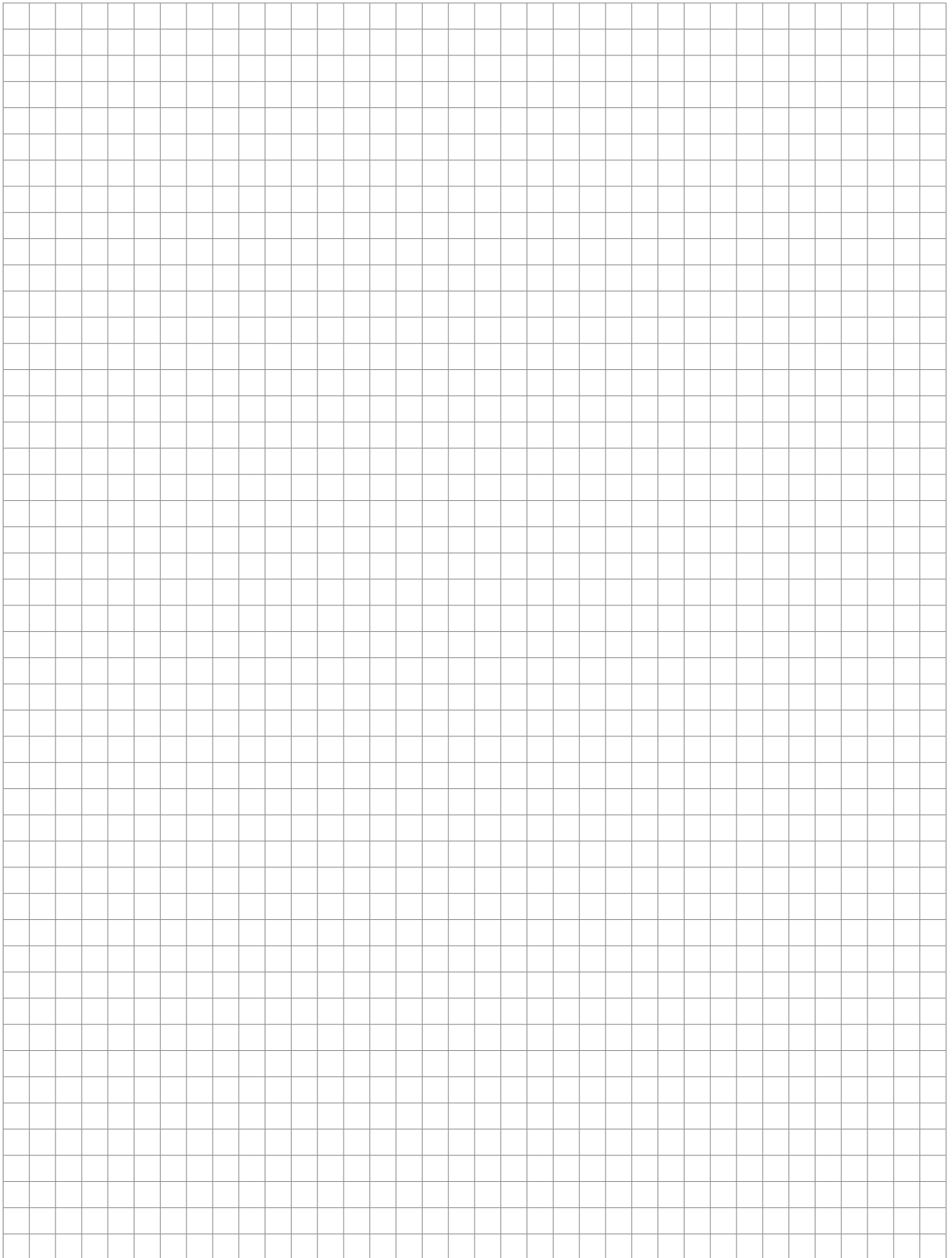



skf.com

® SKF is registered trademark of the SKF Group.

Apple and the Apple logo are trademarks of Apple Inc.

Google Play and the Google Play logo are trademarks of Google Inc.

© SKF Group 2018

The contents of this publication are the copyright of the publisher and may not be reproduced (even extracts) unless prior written permission is granted. Every care has been taken to ensure the accuracy of the information contained in this publication but no liability can be accepted for any loss or damage whether direct, indirect or consequential arising out of the use of the information contained herein.

PUB MT/P1 17855/1 EN · October 2018

Certain image(s) used under license from Shutterstock.com.