

Linear actuator

Magforce STW

Benefits

- Modular
- Robust
- Reliable
- High speed and/or high load
- All metal design



Dimensional drawing

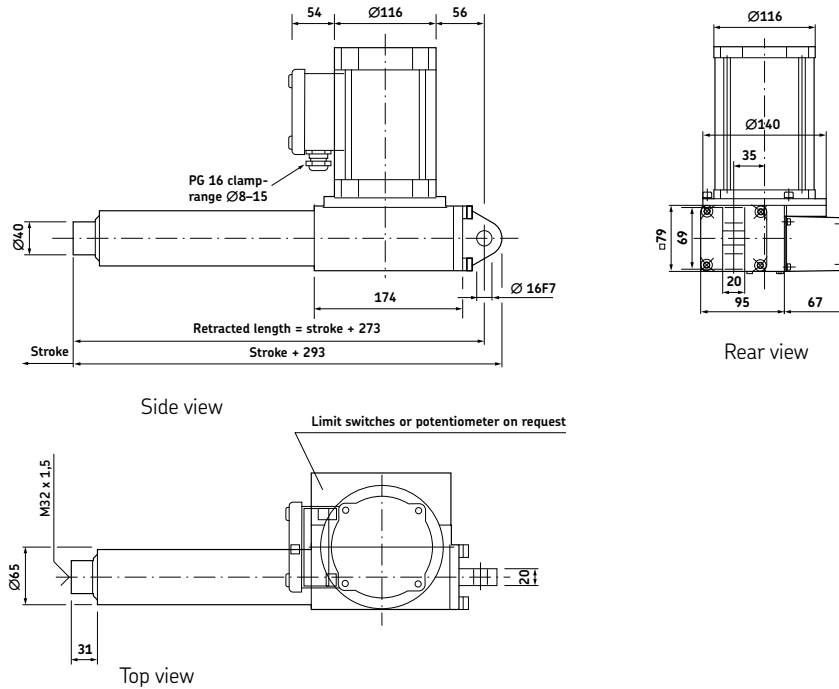

Connecting diagrams

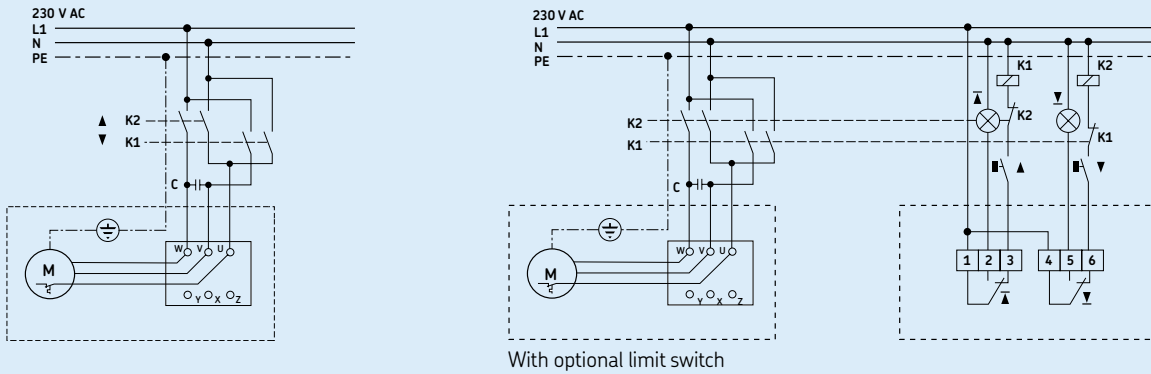

Technical data

	Unit	STW 5007	STW 7010	STW 10020	STW 15040
Push load	N	5 000	7 000	10 000	15 000
Pull load	N	5 000	7 000	10 000	15 000
Speed (at full load)	mm/s	12	8	4	2
Stroke	mm	100 to 700	100 to 700	100 to 700	100 to 700
Retracted length	mm	S+273	S+273	S+273	S+273
Voltage	V AC	230	230	230	230
Power consumption	W	700	710	710	750
Current consumption	A	3,3	3,5	3,5	3,5
Duty cycle	%	15 (1,5/8,5)	10 (1/9)	10 (1/9)	10 (1/9)
Ambient temperature	°C	-10 to +40	-10 to +40	-10 to +40	-10 to +40
Type of protection	IP	54	54	54	54
Weight (at 200 mm stroke)	kg	14,6	14,6	14,6	14,6
Color	-	Silver	Silver	Silver	Silver

Performance diagram

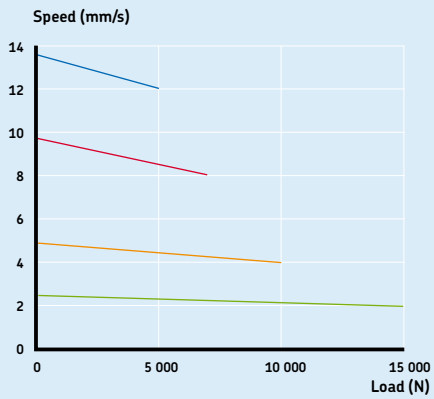

Speed-load diagram

- STW 5007-200
- STW 7010-200
- STW 10020-200
- STW 15040-200

Safety load factor conditions

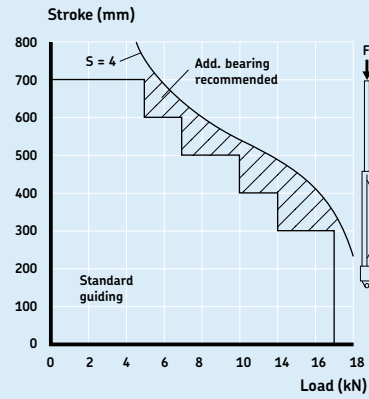

Bending of spindle
S = safety factor Euler 3

Options

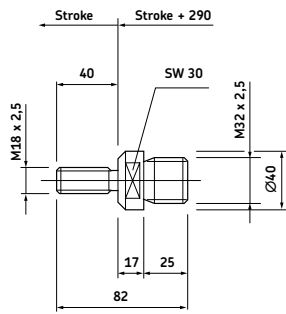

Adapter

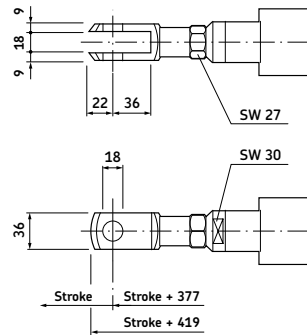

Front attachment

Ordering key

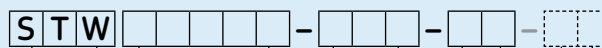

Type

Load:

5 000 N
7 000 N
10 000 N
15 000 N

05007
07010
10020
15040

Stroke (S):

100 mm
200 mm
300 mm
400 mm
500 mm
600 mm
700 mm

100
200
300
400
500
600
700

Option 1:

No option
*Others**

01
XX

Option 2:

No option
Adapterbolt M18 1031,0106
Fork head (including adapterbolt) 1051,9038

O
E
F

Option 3:

No option
Limit switch
Potentiometer (1 000 Ω)
Encoder 1063,0020

0
1
2
3

Options shown in italics are only available on request.

Minimum quantities or additional costs apply for option 1 if shown in italics. For option 2 and 3 please contact your SKF representative.

Example for ordering an actuator without any options: STW05007-100-01.

Example for ordering an actuator with option fork head: STW05007-100-01-F0 (F0= with fork head).

* Example for others XX: *Back up nut, extended motor shaft, low temperature grease...*

Spare parts

	Designation	Order N°
Adapter bolt	ZBE-1031,0106	M/0125265
Fork head	ZBE-1051,9038	M/0124705

